

JET®

Operating Instructions and Parts Manual JWL-1442VS Wood Lathe



WALTER MEIER (Manufacturing) Inc.

427 New Sanford Road
LaVergne, Tennessee 37086
Ph.: 800-274-6848
www.waltermeier.com

Part No. M-708358

Revision D1 11/2010

Copyright © 2010 Walter Meier (Manufacturing) Inc

Warranty and Service

Walter Meier (Manufacturing) Inc., warrants every product it sells. If one of our tools needs service or repair, one of our Authorized Service Centers located throughout the United States can give you quick service. In most cases, any of these Walter Meier Authorized Service Centers can authorize warranty repair, assist you in obtaining parts, or perform routine maintenance and major repair on your JET® tools. For the name of an Authorized Service Center in your area call 1-800-274-6848.

MORE INFORMATION

Walter Meier is consistently adding new products to the line. For complete, up-to-date product information, check with your local Walter Meier distributor, or visit waltermeier.com.

WARRANTY

JET products carry a limited warranty which varies in duration based upon the product (MW = Metalworking, WW = Woodworking).

90 DAY WARRANTY	1 YEAR WARRANTY	Body Repair Kits Bottle Jacks Cable Pullers Cold Saws Hoists-Air Hoists-Electric Metal forming Mill/Drills Milling Machines MW Bandsaws MW Drill Presses MW Finishing Equipment MW Lathes MW Precision Vises	2 YEAR WARRANTY	Palet Trucks Rigging Equip. Service Jacks Stackers Surface Grinders Tapping Trolleys-Air Trolleys-Electric Web Slings Winches-Electric	3 YEAR WARRANTY	WW Benchtop Tools	Beam Clamps Chain Hoist- Manual Lever Hoists Pullers-JCH Models Scissor Lift Tables Screw Jacks Trolleys-Geared Trolleys-Plain Winches-Manual WW Air Filtration WW Bandsaws WW Buffers	5 YEAR WARRANTY	WW Drill Presses WW Dust Collectors WW Dust Filters WW Dust Fittings WW Jointers WW Lathes WW Planers WW Sanders WW Shapers WW Tablesaws	LIFE LIFETIME WARRANTY	Fastening Tools Mechanics Hand Tools Striking Tools Vises (no -precision) Clamps
Warranty reverts to 1 Year Warranty if woodworking (WW) products listed above are used for industrial or educational purposes.											

WHAT IS COVERED?

This warranty covers any defects in workmanship or materials subject to the exceptions stated below. Cutting tools, abrasives and other consumables are excluded from warranty coverage.

WHO IS COVERED?

This warranty covers only the initial purchaser of the product.

WHAT IS THE PERIOD OF COVERAGE?

The general JET warranty lasts for the time period specified in the product literature of each product.

WHAT IS NOT COVERED?

Five Year Warranties do not cover woodworking (WW) products used for commercial, industrial or educational purposes. Woodworking products with Five Year Warranties that are used for commercial, industrial or education purposes revert to a One Year Warranty. This warranty does not cover defects due directly or indirectly to misuse, abuse, negligence or accidents, normal wear-and-tear, improper repair or alterations, or lack of maintenance.

HOW TO GET SERVICE

The product or part must be returned for examination, postage prepaid, to a location designated by us. For the name of the location nearest you, please call 1-800-274-6848.

You must provide proof of initial purchase date and an explanation of the complaint must accompany the merchandise. If our inspection discloses a defect, we will repair or replace the product, or refund the purchase price, at our option. We will return the repaired product or replacement at our expense unless it is determined by us that there is no defect, or that the defect resulted from causes not within the scope of our warranty in which case we will, at your direction, dispose of or return the product. In the event you choose to have the product returned, you will be responsible for the shipping and handling costs of the return.

HOW STATE LAW APPLIES

This warranty gives you specific legal rights; you may also have other rights which vary from state to state.

LIMITATIONS ON THIS WARRANTY

WALTER MEIER (MANUFACTURING) INC., LIMITS ALL IMPLIED WARRANTIES TO THE PERIOD OF THE LIMITED WARRANTY FOR EACH PRODUCT. EXCEPT AS STATED HEREIN, ANY IMPLIED WARRANTIES OR MERCHANTABILITY AND FITNESS ARE EXCLUDED. SOME STATES DO NOT ALLOW LIMITATIONS ON HOW LONG THE IMPLIED WARRANTY LASTS, SO THE ABOVE LIMITATION MAY NOT APPLY TO YOU.

WALTER MEIER SHALL IN NO EVENT BE LIABLE FOR DEATH, INJURIES TO PERSONS OR PROPERTY, OR FOR INCIDENTAL, CONTINGENT, SPECIAL, OR CONSEQUENTIAL DAMAGES ARISING FROM THE USE OF OUR PRODUCTS. SOME STATES DO NOT ALLOW THE EXCLUSION OR LIMITATION OF INCIDENTAL OR CONSEQUENTIAL DAMAGES, SO THE ABOVE LIMITATION OR EXCLUSION MAY NOT APPLY TO YOU.

Walter Meier sells through distributors only. The specifications in Walter Meier catalogs are given as general information and are not binding. Members of Walter Meier reserve the right to effect at any time, without prior notice, those alterations to parts, fittings, and accessory equipment which they may deem necessary for any reason whatsoever. JET®-branded products are not sold in Canada by Walter Meier.

Table of Contents

Warranty and Service.....	2
Table of Contents	3
Warnings.....	4
Introduction	6
Specifications	6
Shipping Contents	7
Contents of the Shipping Containers.....	7
Unpacking and Clean-Up	7
Assembly	7
Stand Legs	7
Tool Rest	8
Stand Shelf.....	8
Grounding Instructions	9
Controls and Features.....	10
Lathe Tools	12
Operations	13
Stock Selection	13
Roughing Out.....	13
Beads.....	14
Coves.....	14
“V” Cuts.....	14
Sanding and Finishing	15
Face Plate or Chuck	16
Wood Selection.....	16
Checks and Cracks	16
Distortion	16
To Shape the Outside of a Bowl.....	17
To Shape the Interior of a Bowl	18
Adjustments	19
Adjusting the Clamping Mechanism.....	19
Changing the Belt and Bearings	19
Optional Accessories	20
Safety Guard.....	20
Tool Basket.....	20
Parting.....	14
Tools for Bowl Turning	16
Sanding and Finishing a Bowl	18
Troubleshooting.....	21
Parts.....	21
Ordering Replacement Parts.....	21
Bed Assembly Parts List.....	22
Headstock Assembly – Parts List.....	23
Headstock Assembly	25
Stand Assembly	26
Safety Guard Assembly	27
Basket Assembly.....	27
Wiring Diagram.....	28
Appendix – Indexer Positions	29

The specifications in this manual are given as general information and are not binding. Walter Meier (Manufacturing) Inc., reserves the right to effect, at any time and without prior notice, changes or alterations to parts, fittings, and accessory equipment deemed necessary for any reason whatsoever.



Warnings

1. Read and understand the entire owner's manual before attempting assembly or operation.
2. This wood lathe is designed and intended for use by properly trained and experienced personnel only. If you are not familiar with the proper and safe operation of a wood lathe, do not use it until the proper training and knowledge have been obtained.
3. Always wear approved safety glasses/face shields while using this machine.
4. Make certain the machine is properly grounded.
5. Before operating the machine, remove tie, rings, watches, other jewelry, and roll sleeves up past the elbows. Remove all loose clothing and confine long hair. Do **not** wear gloves.
6. Keep the floor around the machine clean and free of scrap material, oil and grease.
7. Keep machine guards in place at all times when the machine is in use. If removed for maintenance purposes, use extreme caution and replace the guards immediately.
8. Do **not** over reach. Maintain a balanced stance at all times, so that you do not fall or lean against blades or other moving parts.
9. Make all machine adjustments or maintenance with the machine unplugged from the power source.
10. Use the right tool. Do not force a tool or attachment to do a job that it was not designed to do.
11. Replace warning labels if they become obscured or removed.
12. Make certain the switch is in the **OFF** position before connecting the machine to the power supply.
13. Give your work undivided attention. Looking around, carrying on a conversation and "horse-play" are careless acts that can result in serious injury.
14. Keep visitors a safe distance from the work area.
15. Use recommended accessories; improper accessories may be hazardous.
16. Read and understand warnings posted on the machine and in this manual. Failure to comply with all of these warnings may cause serious injury.
17. Some dust created by power sanding, sawing, grinding, drilling and other construction activities contain chemicals known to cause cancer, birth defects or other reproductive harm. Some examples of these chemicals are:
 - Lead from lead based paint.
 - Crystalline silica from bricks, cement and other masonry products.
 - Arsenic and chromium from chemically treated lumber.

Your risk of exposure varies, depending on how often you do this type of work. To reduce your exposure to these chemicals, work in a well-ventilated area and work with approved safety equipment, such as face or dust masks that are specifically designed to filter out microscopic particles.
18. Do not operate this lathe while under the influence of drugs, alcohol or any medication.
19. Keep tools sharp and clean for safe and best performance. Dull tools can grab in the work and be jerked from the operator's hands causing serious injury.
20. Check the condition of the stock to be turned. Make sure it is free of knots, warpage, checked ends, improperly made or cured glue joints and other conditions which can cause it to be thrown out of the lathe.
21. Securely fasten spur/live centers to the material being used.
22. Check centers and center sockets in the headstock and tailstock to be sure they are free of dirt or rust and oil lightly before inserting centers.

Warnings

23. Test each set-up by revolving the work by hand to insure it clears the tool rest and bed. Check the setup at the lowest speed before increasing it to the operating speed.
24. Use the correct cutting tool for the operation to be performed and keep all tools sharp.
25. Use low speeds for roughing and for long or large diameter work. If vibration occurs, stop the machine and correct the cause. See the speed recommendation chart below:

Diameter of Work	Roughing RPM	General Cutting RPM	Finishing RPM
Under 2"	1500	3000	3000
2 to 4"	600	1500	2300
4 to 6"	450	1100	1500
6 to 8"	450	600	1100
8 to 10"	450	600	850
10 to 12"	450	600	850
12 to 14"	450	450	600

Speed Recommendations

26. When sanding, remove the tool rest from the machine, apply light pressure and use a slow speed to avoid heat build up.
27. When turning large diameter pieces, such as bowls, always operate the lathe at low speeds. See the speed recommendation chart.
28. Do not attempt to engage the spindle lock pin until the spindle has stopped. If leaving the machine area, turn it off and wait until the spindle stops before departing.
29. Make no adjustments except speed changes with the spindle rotating and always disconnect the machine from the power source when performing maintenance to avoid accidental starting or electrical shock.
30. Provide for adequate space surrounding work area and non-glare, overhead lighting.
31. When stopping the lathe, never grab the part or faceplate to slow it down. Let the work coast to a stop.
32. Use only JET factory authorized replacement parts and accessories; otherwise, the warranty and guarantee are null and void.
33. Do not use this JET wood lathe for other than its intended purpose. If used for other purposes, Walter Meier (Manufacturing) Inc., disclaims any real or implied warranty and holds itself harmless from any injury that may result from that use.

Familiarize yourself with the following safety notices used in this manual:

CAUTION This means that if precautions are not heeded, it may result in minor injury and/or possible machine damage.

WARNING This means that if precautions are not heeded, it may result in serious injury or possibly even death.

Introduction

This manual is provided by Walter Meier (Manufacturing) Inc., covering the safe operation and maintenance procedures for a Model JWL-1442VS Wood Lathe. This manual contains instructions on installation, safety precautions, general operating procedures, maintenance instructions and parts breakdown. This machine has been designed and constructed to provide years of trouble free operation if used in accordance to instructions set forth in this manual. If there are any questions or comments, please contact either your local supplier or Walter Meier. Walter Meier can also be reached at our web site: www.waltermeier.com.

Specifications

Model NumberJWL-1442VSK
Stock Number 708358K
Motor TEFC 1HP, 1PH, 115V/230V, **Prewired 115V**. 60Hz, 11/5.5A
Switchmanual, paddle style with lockout

Construction:

Headstock cast iron
Tailstock cast iron
Bed cast iron
Tool Rest cast iron
Stand cast iron

General Dimensions:

Swing Over Bed (in.) 14
Swing Over Tool Rest Base (in.) 10
Distance Between Centers, maximum (in.) 42

Headstock:

Spindle Thread, Inboard (in.) 1 x 8TPI
Spindle Thread, Outboard (in.) 3/4-16 UNF (L. H.)
Hole through Spindle (in.) 3/8
Spindle Center to Floor, approx. (in.) 43-1/2
Spindle Taper #2 Morse
Headstock Rotation (deg.) 360
Positive Stops (deg.) 45, 90, 135, 180, 270, 360
Spindle Speeds (RPM) (eight): 450, 600, 850, 1100, 1500, 1900, 2300, 3000
Drive Pulley System Reeves
Locking System cam (tool-less)
Faceplate Provided (in.) 6
Indexing positive locking, 10 degree increments

Tailstock:

Hole through Tailstock (in.) 3/8
Tailstock Taper #2 Morse
Ram Travel (in.) 4
Locking System cam (tool-less)

Tool Rest:

Base Locking System cam (tool-less)
Tool Rest Provided (in.) 12

Weight:

Net, approximate (lbs.) 355
Shipping, approximate (lbs.) 375

The above specifications were current at the time this manual was published, but because of our policy of continuous improvement, Walter Meier reserves the right to change specifications at any time and without prior notice, without incurring obligations.

⚠WARNING Read and understand the entire contents of this manual before attempting assembly or operation! Failure to comply may cause serious injury.

Shipping Contents

Contents of the Shipping Containers

- 1 Lathe with Leg Set
- 1 Tailstock
- 1 Headstock
- 1 Face Plate
- 1 Tool Rest Body
- 1 Accessory Package
- 1 Owner's Manual and Warranty Card

Accessory Package Box

- 1 Live Center
- 1 Spur Center
- 1 Index Pin
- 1 Wrench
- 1 Drift Rod
- 1 Tool Rest
- 1 Tool Rest Extension
- 4 Adjustable Feet

Unpacking and Clean-Up

1. Remove the shipping container. Do not discard any shipping material until the lathe is set up and running properly.
2. Remove tailstock, tool rest and headstock before lifting; see "Adjusting the Clamping Mechanism" on Page 19 on how to remove the tailstock, headstock or tool rest.
3. Remove hex cap bolts from skid bottom and lift the lathe bed, with the help from another person, off the skid and onto the edge of a workbench, as shown in Figure 1.
4. Clean all rust protected surfaces with a cleaner-degreaser. Clean under the headstock, tailstock and tool rest body.

Assembly

Stand Legs

At this point the headstock, tailstock and tool rest should be removed. With help from another person, lift the lathe bed and place onto a workbench.

1. Angle lathe bed so that stand leg mounting holes are accessible, see Figure 1.



708358K



Contents of Accessory Package

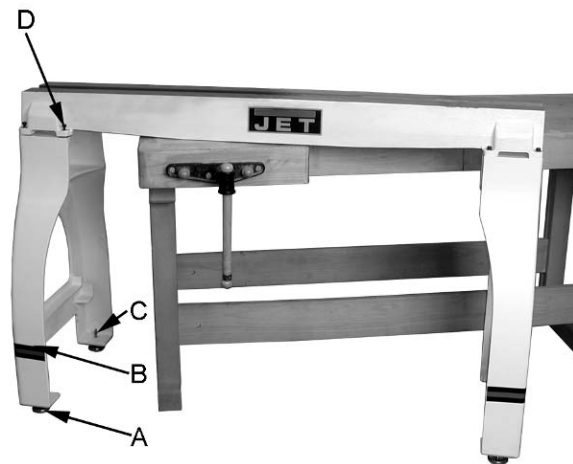

Figure 1

2. Thread adjustable feet (A, Fig. 1) into stand leg (B, Fig. 1). There is a flat spot on the shaft near the foot that will accommodate a wrench. Thread a hex nut (C, Fig. 1) onto shaft and leave loose for now.
3. Mount the leg to lathe bed with four 5/16" flat washers and four 5/16"-18 x 1-1/2" hex socket cap screws (D, Fig. 1).
4. Repeat for the other leg.
5. Adjust the feet so that the lathe rests evenly on the floor, and tighten the nuts.
6. Reinstall headstock, tailstock and tool rest.



Figure 2

Tool Rest

Secure tool rest (A, Fig. 2) to tool rest body (B, Fig. 2) by tightening handle (C, Fig. 2).

Note: For some turning applications, you may need to assemble the tool rest extension between the tool rest body and tool rest.

Stand Shelf

You can make an extra shelf that rests between the legs if you wish, see Figure 3. It will be useful for storing lathe accessories, or adding sand bags for some extra weight. The two 2x4's should be 55-3/4" long. The plywood should be ripped into two equal pieces 27-13/16"L x 17"W so that it can be assembled between the legs. Use screws to attach the plywood to the 2x4 supports.

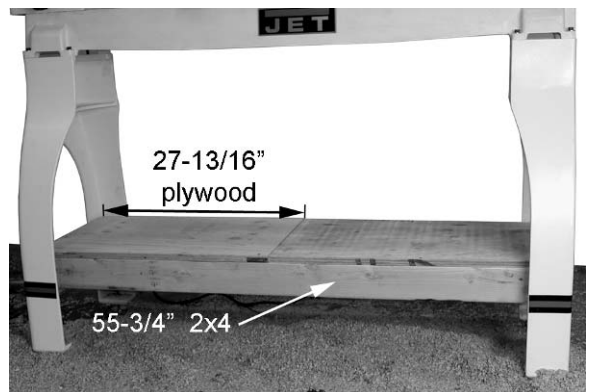

Figure 3

Grounding Instructions

CAUTION This tool must be grounded while in use to protect the operator from electric shock.

In the event of a malfunction or breakdown, grounding provides a path of least resistance for electric current to reduce the risk of electric shock. This tool is equipped with an electric cord having an equipment-grounding conductor and a grounding plug. The plug must be plugged into a matching outlet that is properly installed and grounded in accordance with all local codes and ordinances.

Do not modify the plug provided. If it will not fit the outlet, have the proper outlet installed by a qualified electrician.

Improper connection of the equipment-grounding conductor can result in a risk of electric shock. The conductor, with insulation having an outer surface that is green with or without yellow stripes, is the equipment-grounding conductor. If repair or replacement of the electric cord or plug is necessary, do not connect the equipment-grounding conductor to a live terminal.

Check with a qualified electrician or service personnel if the grounding instructions are not completely understood, or if in doubt as to whether the tool is properly grounded. Use only three wire extension cords that have three-prong grounding plugs and three-pole receptacles that accept the tool's plug.

Repair or replace a damaged or worn cord immediately.

115 Volt Operation

As received from the factory, your sander is ready to run at 115-volt operation. This sander, when wired for 115 volts, is intended for use on a circuit that has an outlet and a plug that looks the one illustrated in Figure A. A temporary adapter, which looks like the adapter as illustrated in Figure B, may be used to connect this plug to a two-pole receptacle, as shown in Figure B if a properly grounded outlet is not available.

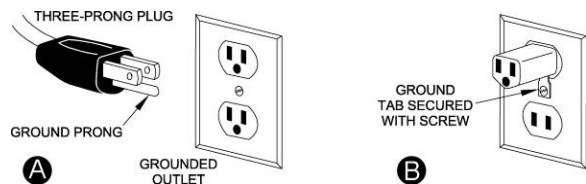

The temporary adapter should only be used until a properly grounded outlet can be installed by a qualified electrician. **This adapter is not applicable in Canada.** The green colored rigid ear, lug, or tab, extending from the adapter,

must be connected to a permanent ground such as a properly grounded outlet box, as shown in Figure B.

The use of an extension cord is not recommended. However, if you must use one make sure your extension cord is in good condition. Be sure to use one heavy enough to carry the current your machine will draw. An undersized cord will cause a drop in the line voltage resulting in power loss and overheating. The following table shows the correct size to use depending on the cord length needed and the nameplate ampere rating. If in doubt, use the next heavier gauge. Remember, the smaller the gauge number, the heavier the cord.

Volts	Total Length of Cord in Feet			
	25	50	100	150
AWG				
12-16A	14	12	Not Recommended	

230 Volt Operation

If 230V, single-phase operation is desired, the following instructions must be followed:

1. Disconnect the machine from the power source.
2. This lathe is supplied with four motor leads that are connected for 115V operation, as shown in Figure A. Reconnect these four motor leads for 230V operation, as shown in Figure B.
2. The 115V attachment plug (A), supplied with the lathe, must be replaced with a UL/CSA listed plug suitable for 230V operation (D). Contact your local Authorized Service Center or qualified electrician for proper procedures to install the plug. The lathe must comply with all local and national codes after the 230-volt plug is installed.
3. The lathe with a 230 volt plug should only be connected configuration (D). No adapter is available or should be used with the 230-volt plug.

Important: In all cases (115 or 230 volts), make certain the receptacle in question is properly grounded. If you are not sure, have a registered electrician check the receptacle.

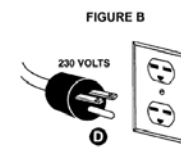
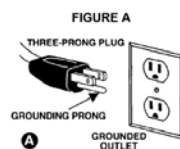
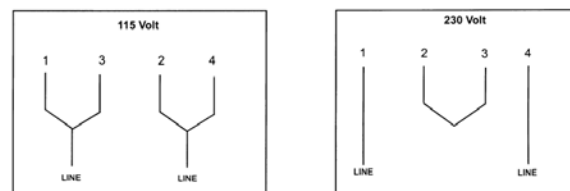

Controls and Features

- E. **Headstock Lock Handle:** (E, Fig. 4)
Locks the head in position. Unlock the handle to position the head in any location along the lathe bed. Tighten handle when properly positioned.
- F. **Headstock Indexing Pin:** (F, Fig. 4)
Turn the knurled knob counter-clockwise to unlock the plunger. Pull the knob out to release the headstock. Unlock the headstock-locking handle and rotate the headstock. Turn knurled knob clockwise until it stops to lock plunger.
- G. **Headstock Spindle Lock:** (G, Fig. 5)
Push in pin to keep the spindle from turning.

CAUTION Never press the headstock spindle lock while the spindle is turning!

- H. **Headstock On/Off Switch:** (H, Fig. 5)
Flip the switch up to turn "ON" the lathe. Flip the switch down to turn the lathe "OFF".
- I. **Headstock On/Off Switch Key:** (I, Fig. 5)
Remove key when in the "OFF" position. The switch will not work until key is reinstalled.
- J. **Headstock Speed Selector:** (J, Fig. 5)
Place handle directly above the desired RPM speed. Pull handle out and move to the desired speed, see Figure 6.

CAUTION Only change speeds while the spindle is turning!

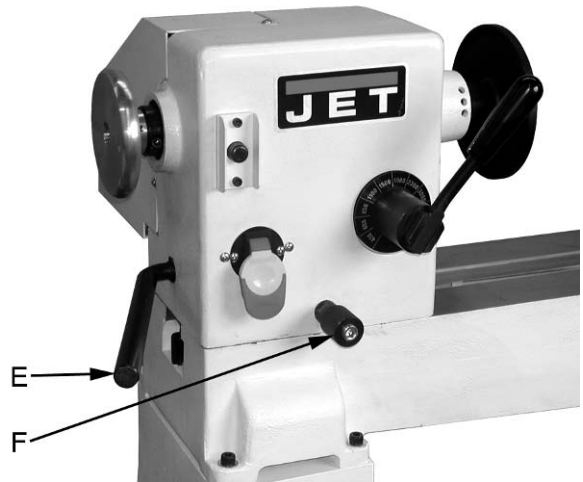

Figure 4

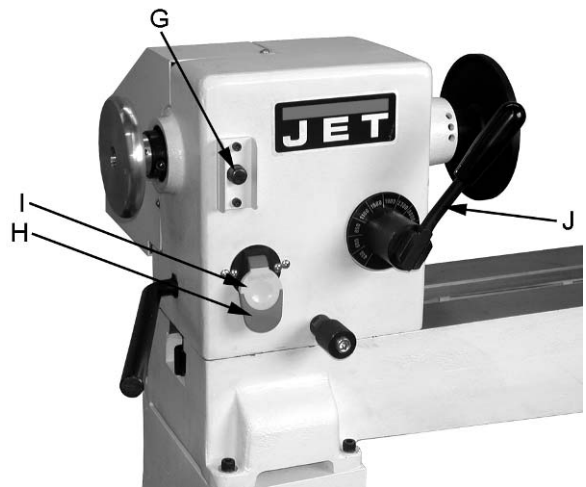

Figure 5

Diameter of Work	Roughing RPM	General Cutting RPM	Finishing RPM
Under 2"	1500	3000	3000
2 to 4"	600	1500	2300
4 to 6"	450	1100	1500
6 to 8"	450	600	1100
8 to 10"	450	600	850
10 to 12"	450	600	850
12 to 14"	450	450	600

Figure 6

K. **Headstock Faceplate:** (K, Fig. 7)
Used for turning bowls. There are a number of screw holes for mounting the workpiece. Thread the faceplate onto the spindle in a clockwise direction. Remove the faceplate by pushing in headstock spindle lock and using the provided wrench on faceplate flats.

L. **Headstock Spur Center:** (L, Fig. 7)
Used for turning between centers. Spindle taper is MT-2. Remove spur center by inserting drift rod through the opposite end of the spindle and knocking spur center out.

M. **Headstock Indexing Hole:** (M, Fig. 7)
Thread indexing pin into the indexing hole making sure that it locates in the spindle hole. There are 12 holes in the spindle 30° apart. Three holes in the headstock casting accept the indexing pin. These holes are 20° apart. The combination of holes will allow you to mark your workpiece for evenly spaced features. See chart on page 29.

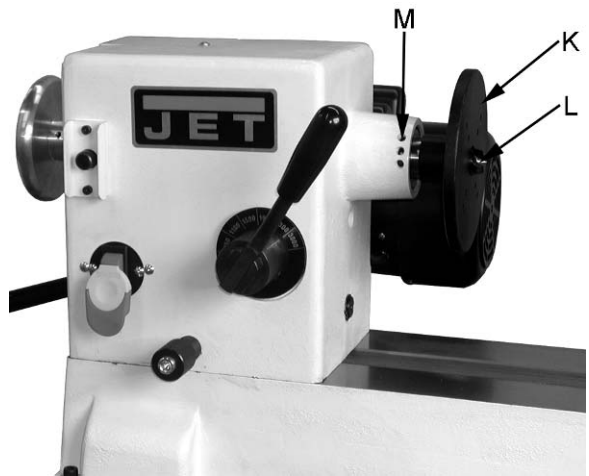

Figure 7

CAUTION Never start the lathe with the index pin engaged in the spindle!

N. **Tool Rest Body Lock Handle:** (N, Fig. 8)
Locks the tool rest body in position. Unlock handle to position the tool rest in any location along lathe bed. Tighten handle when properly positioned.



Figure 8

O. **Tool Rest Lock Handle:** (O, Fig. 8)
Locks the tool rest in position. Unlock the handle to position tool rest at a specific angle, or height. Tighten handle when properly positioned.

P. **Tailstock Lock Handle:** (P, Fig. 9)
Locks the tailstock in position. Unlock handle to position the tool rest in any location along lathe bed. Tighten handle when properly positioned.

Q. **Tailstock Quill Lock Handle:** (Q, Fig. 9)
Locks the tailstock quill in position. Unlock handle to position the quill. Tighten handle when properly positioned.

R. **Tailstock Quill Handwheel:** (R, Fig. 9)
Turn the handwheel to position the quill. The tailstock quill lock handle must be loose to position quill.

S. **Tailstock Live Center:** (S, Fig. 9)
Used for turning between centers. Quill taper is MT-2. Remove live center by retracting the quill until live center loosens.

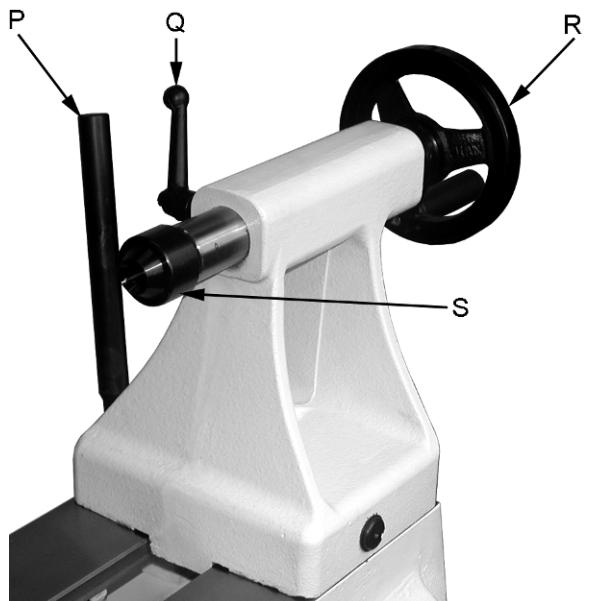

Figure 9

Lathe Tools

If possible, select only high quality, high speed steel turning tools with long handles. As one becomes proficient in turning, a variety of specialty tools for specific applications can be acquired. The following tools provide the basics for most woodturning projects.

Roughing Gouge — used for rapidly cut raw wood into round stock, see Figure 10.

Deep Fluted Bowl Gouge — used for turning bowls and plates, see Figure 10.

Spindle Gouge — used for turning beads, coves and other details, see Figure 10.

Spear — fine scraping and delicate operations, such as the forming of beads, parallel grooves and shallow vees, etc, see Figure 10.

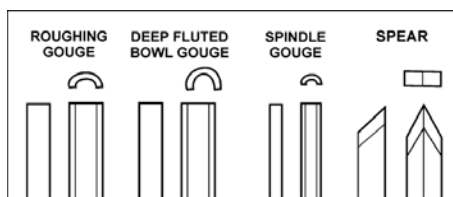

Figure 10

Skew — used to make vees, beads, etc., see Figure 11.

Square Scraper — used for diameter scraping and featureless scraping, etc, see Figure 11.

Large Domed Scraper — used to reduce ridges on the interior of bowls, round edges of bowls, etc, see Figure 11.

Parting Tool — used to cut directly into the material, or to make a cut off. Also used for scraping and to set diameters, see Figure 11.

For safety and best performance, **keep tools sharp**. If a tool stops cutting, or requires excessive pressure to make a cut, it needs to be sharpened. A number of brand name sharpening jigs and fixtures are available, however, a wood turner should learn to sharpen tools freehand.

Mounting Workpiece Between Centers

Spindle turning takes place between the centers of the lathe. It requires a spur center in the headstock and a live center in the tailstock.

1. With a ruler locate and mark the center on each end by going corner to corner, see Figure 12. Accuracy is not critical on full rounds but extremely important on stock where square sections are to remain. Put a dimple in each end of the stock with an awl or nail.
2. Extremely hard woods may require kerfs cut into the spur drive end of stock, see Figure 12. You may need to drive the spur center into the stock with a wood mallet. **Note:** Never drive stock onto spur while it is mounted in the lathe spindle.
3. Install workpiece by inserting the attached spur center into the spindle taper on the headstock.
4. Bring tailstock into position, lock it to the bed, and advance quill with the handwheel in order to seat the live center into the workpiece. Lock the quill in place. Make sure the live center point is centered on your mark.
5. Move tool rest into position. It should be parallel to workpiece, approximately at the centerline, and approximately 1/8" from the closest part of the workpiece. Lock tool rest body and tool rest in place.
6. Rotate workpiece by hand to check for proper clearance from tool rest. **Note:** You may want to trim off the corners of a square workpiece to make turning a little easier.
7. Start lathe at **lowest** speed and bring it up to the appropriate RPM for the size of stock, see Figure 6 page 11.

The position of the tool rest can be varied to suit the work and operator. After you become experienced with setting tool rest changing the position will become second nature for the workpiece and comfort of the user.

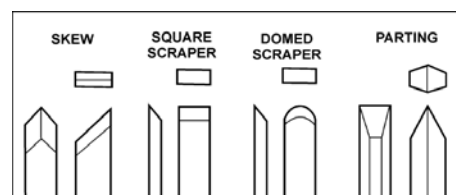

Figure 11

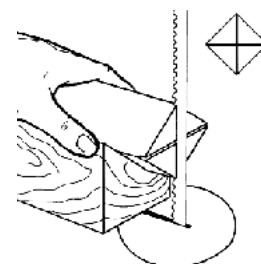

Figure 12

Operations

Stock Selection

Stock for spindles should be straight grained and free of checks, cracks, knots and other defects. It should be cut 1/8" to 1/4" larger than the finished diameter and may require additional length to remove ends if required. Larger stock should have the corners removed to produce an octagon making the piece easier to rough down to a cylinder, see Figure 13.

Roughing Out

1. Use a large roughing gouge and begin cutting about 2" from the tailstock end of the workpiece. Place the tool on the tool rest with the heel of the tool on the surface to be cut.
2. Slowly and gently raise tool handle until cutting edge comes into contact with the workpiece. Work to the right towards the end of the workpiece. You never want to start at the end of a workpiece.
3. Now continue to work the rest of the workpiece. Roll the flute (hollowed-out portion) of the tool in the direction of the cut, see Figure 14. Make long sweeping cuts in a continuous motion to rough the piece down to a cylinder. Keep as much of the bevel of the tool as possible in contact with the workpiece to ensure control and avoid catches.

Note: Always cut downhill, or from large diameter to small diameter. Always work *toward* the end of a workpiece, never start cutting at the end.

4. Once the workpiece is roughed down to a cylinder, smooth it with a large skew. Place the cutting point near the center of the chisel and high on the workpiece, see Figure 15. Touching one of the points of the skew to the spinning workpiece may cause a catch and ruin the workpiece.
5. Add details to the workpiece with skew, spindle gouge, etc.



Figure 13



Figure 14



Figure 15

Beads

1. Place the parting tool on the tool rest and move the tool forward to make the full bevel of the tool contact the workpiece. Gently raise handle to make cut to the appropriate depth.
2. Repeat for other side of the bead.
3. Using a small skew or spindle gouge, start in the center between the two cuts and cut down each side to form the bead. Roll the tool in direction of cut.

Coves

1. Use a spindle gouge. With the flute of the tool at 90 degrees to the workpiece, touch the center of the cutting edge to the workpiece and roll in towards the bottom of the cove. **Stop at the bottom;** attempting to go up the opposite side may cause the tool to catch.
2. Move the tool over the desired width of the cove.
3. With the flute facing the opposite direction, repeat step 1 for other side of cove. Stop at bottom of cut.

"V" Cuts

1. Use the long point of the skew. **Note:** Do not press the long point of the skew directly into the workpiece to create the "V"; this will result in a burned or burnished "V" with fibers being rolled up at both sides.
2. Lightly mark the center of the "V" with the tip of the skew.
3. Move the point of the skew to the right half of the desired width of your cut.
4. With the bevel parallel to the right side of the cut, raise the handle and push the tool in to the desired depth.
5. Repeat from the left side. The two cuts should meet at the bottom and leave a clean "V" cut.
6. Additional cuts may be taken to add to either the depth or width of the cut.

Parting

Place parting tool on tool rest and raise the handle until it starts to cut and continue to cut to the desired depth.

If the cut is deep a clearance cut should be made alongside the first cut to prevent the tool tip from burning.

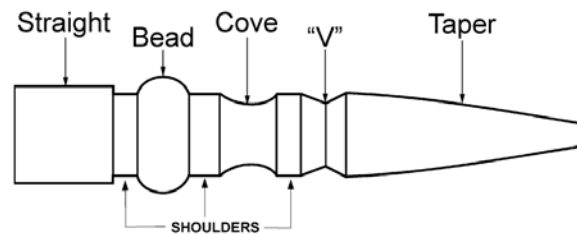

Figure 16

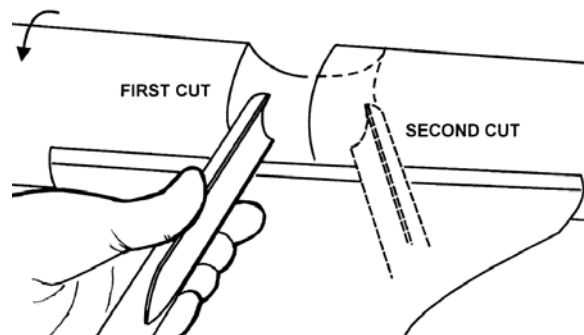

Figure 17

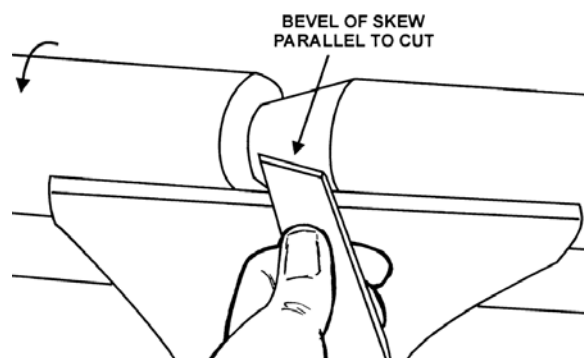

Figure 18

Sanding and Finishing

Leaving clean cuts will reduce the amount of sanding required. Begin with a fine sandpaper (120 grit or finer). Coarser sandpaper will leave deep scratches that are difficult to remove, and dull crisp details. Fold the sandpaper into a pad; do not wrap sandpaper around your fingers or the workpiece.

To apply a finish, the workpiece can be left on the lathe. Turn off lathe and use a brush, or cloth to apply the finish. Remove excess finish before restarting lathe. Allow drying and sanding again with 320 or 400 grit sandpaper. Apply additional coats of finish and buff.

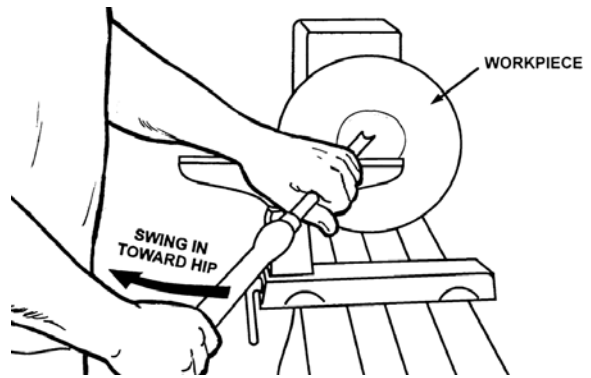

Figure 19

Face Plate and Bowl Turning

Face plate turning is normally done on the inboard side of the headstock over the bed see Figure 19. You must pivot the headstock 180° for larger workpieces.

Mounting Stock

Use of a face plate is the most common method for holding a block of wood for turning bowls, and plates.

1. Select stock at least 1/8" to 1/4" larger than the dimension on the desired finished workpiece.
2. True one surface of the workpiece for mounting against the face plate. It is best to leave extra stock against the faceplate that can be cut off when the workpiece is finished.
3. Using the faceplate as a template, mark the location of the mounting holes, and drill pilot holes of the appropriate size. If the mounting screws on the faceplate interfere with the workpiece, a waste block can be mounted to the faceplate and then the waste block mounted to the workpiece by gluing or screwing, see Figure 20.
4. Both waste block and workpiece should have good flat surfaces.
5. Push in on the spindle lock and thread face plate and workpiece onto the spindle. Tighten setscrews in the faceplate when secure.

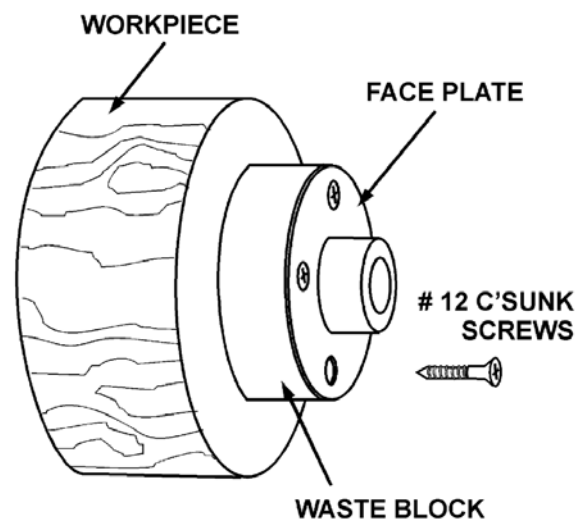

Figure 20

Face Plate or Chuck

While faceplates are the simplest, most reliable method of holding a block of wood for turning, chucks can also be used. A chuck is not a requirement but is handy when working on more than one piece at a time. Rather than removing screws, you simply open the chuck and change workpieces. The most popular ones are four jaw scroll chucks with a variety of jaws to accommodate different size tenons. Most also come with a screw chuck as well.

Wood Selection

Firewood is the cheapest, most widely available stock to use while learning to turn bowls. Develop skill with each tool before attempting to make a finished piece. It is best to start with dry wood, without worrying about drying or distortion. Once turning becomes comfortable, try green wood, which cuts very easily. As the turner gains experience, he or she will find extraordinary grain and figure in the form of burls, crotches and bark inclusions.

Checks and Cracks

Green wood will check and crack. For best results, leave logs in as long lengths as you can handle. As the material starts to dry, surface cracks will develop on the ends of the log. Cut off two to three inches and you should find good, sound wood. Also, cut the log in half along the pith to avoid having it in the finished piece. Most checks radiate from the pith. As you turn bowls from green wood, make sure you maintain a consistent wall thickness throughout the piece. Leaving a piece thick in some areas and thin in others will cause the wood to dry unevenly and promote checks and cracks.

Distortion

Distortion is a problem associated with turning green wood. It will vary from one type of wood to the next. Typically, fruitwoods tend to distort more than others do. It also varies with the time of year the tree was cut and how the logs are stored.

Tools for Bowl Turning

The deep fluted bowl gouge is the most essential and versatile tool for most bowl and faceplate style turning. The bowl gouge is heavier and easier to control than other types of gouges. It also allows removal of wood much faster and with less vibration than other gouges. Most average sized bowl work can be accomplished with a 3/8" or 1/2" bowl gouge. A 1/4" bowl gouge is best suited for smaller bowls and light finishing cuts. Larger 3/4" and 1" bowl gouges are only used for extremely large pieces.

Large domed scrapers can also be used to help clean up the interior surfaces of bowls. A light touch with the scraper slightly tilted will eliminate some of the ridges left by a bowl gouge.

To Shape the Outside of a Bowl

Odd shaped burls, crotches and other irregular shaped blanks require special preparation before mounting in a chuck, or onto a faceplate.

1. Remove the bark, if there is any, from what appears to be the center of the top of workpiece.
2. Drive the spur center into the top of the workpiece with a wood mallet.
3. Slip the spur center into the headstock taper and bring the tailstock, with a live center, into position. Lock the tailstock to the bed and advance the spindle in order to seat the cup center into workpiece, see Figure 21. Tighten the quill lock.
4. Position the tool support below the centerline and about 1/4" from the workpiece. **Note:** For larger outboard turning, an optional outboard turning stand is used to place the tool support, see your JET distributor.
5. Turn the workpiece by hand to ensure proper clearance.
6. Start the lathe at the lowest speed and bring it up to the maximum safe speed for the size of work to be turned, see Figure 6 on page 11. If the machine starts to vibrate, lower the speed until the vibration stops.
7. Rough out the outside of the bowl with the 1/2" deep fluted bowl gouge, holding the tool firmly against your hip. For best control, use your whole body to move the gouge through the workpiece.
8. As the bowl takes shape, work on the bottom (tailstock end) to accommodate attaching a face plate, see Figure 21.
9. Turn a short tenon (about 1/8" long) the size of the hole in the faceplate, see Figure 21. This will allow centering the workpiece when the faceplate is attached. **Note:** If you plan to use a chuck, turn a tenon of appropriate length and diameter to fit your chuck.
10. Stop the lathe, remove the workpiece and attach the face plate, or chuck.
11. Finish turning the outside of the bowl with 1/2" or 3/8" bowl gouge. Leave additional material at the base of the bowl for support while turning the interior. This will be removed later.

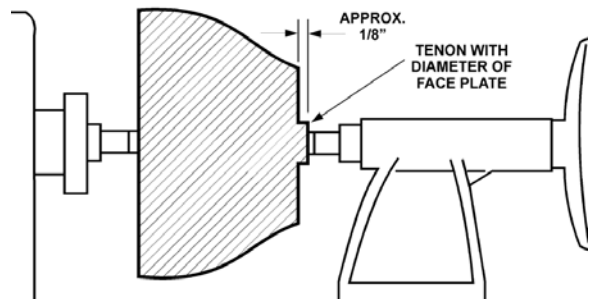

Figure 21

To Shape the Interior of a Bowl

1. Stop the lathe and move the tailstock away. Remove the center from the tailstock to prevent bumping it with your elbow.
2. Adjust the tool support in front of the bowl just below the centerline, at a right angle to the lathe bed.
3. Rotate the workpiece by hand to check the clearance.
4. Face off the top of the bowl by making a light shearing cut across the workpiece, from rim to center.
5. Place the 1/2" bowl gouge on the tool rest at the center of the workpiece with the flute facing the top of the bowl. The tool handle should be level and pointed toward four o'clock, see Figure 22.
6. Use your left hand to control the cutting edge of the gouge, while your right hand swings the tool handle around towards your body, see Figure 22.

The flute should start out facing the top of the workpiece, and rotate upward as it moves deeper into the bowl to maintain a clean even curve.

As the tool goes deeper into bowl, progressively work out toward the rim. It may be necessary to turn the tool rest into the workpiece, as you get deeper into the bowl.

Note: Try to make one, very light continuous movement from the rim to the bottom of the bowl to ensure a clean, sweeping curve through the workpiece. Should there be a few small ridges remaining, a light cut with a large domed scraper can even out the surface.

7. Develop the wall thickness at the rim and maintain it as you work deeper into the bowl. When the interior is finished, move the tool support to the exterior to re-define the bottom of the bowl. General rule of thumb: the base should be approximately 1/3 the overall diameter of the bowl.
8. Work the tight area around the faceplate or chuck with 1/4" bowl gouge.

Sanding and Finishing a Bowl

1. Remove the tool rest and begin with a fine grit sandpaper (120 grit) and progress through each grit, using only light pressure.

Coarser sandpaper tends to leave deep scratches that are hard to eliminate. Use power-sanding techniques to avoid concentric sanding marks around your finished piece. Avoid rounding over the rim and foot with sandpaper. Try to keep the details crisp. Finish sanding with 220 grit.

2. Remove sanding dust with tack rags, or compressed air and, with the lathe turned off, apply the first coat of finish. Let it stand for several minutes and wipe off the excess. Allow it to dry before sanding again with 320 or 400 grit sandpaper.
3. Turn lathe back on and make a separation cut through the base. Stop at about 3" and use a small fine tooth saw to separate the bowl from the waste.
4. Apply additional finish coats and allow to dry before buffing.

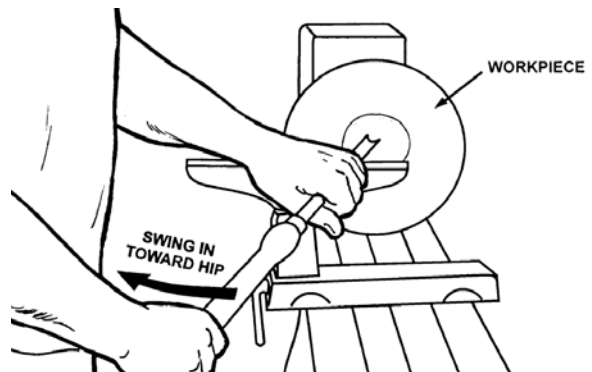

Figure 22

Adjustments

Adjusting the Clamping Mechanism

The clamps are pre-set at the factory and should not need any adjustment. However, if adjustment is needed, remove the stud (A, Fig. 23). Loosen the locking handle and slide the headstock, tailstock or tool rest to the edge of the bed and slightly turn the hex nut (B, Fig. 23). Slide back into position and test the handle to make sure it securely locks.

Changing the Belt and Bearings

Changing belt and bearings can be a difficult task, and should be performed by a JET authorized repair station. Remove headstock and take into a repair station for servicing.

1. Place the belt in its highest speed range. **Do not** change speeds while changing the belt or bearings.
2. Remove the belt cover, and remove the belt from the lower pulley, see Figure 24.
3. Loosen the two setscrews in the handwheel enough to unthread the handwheel (C, Fig. 24).
4. Loosen the socket head cap screw enough to unthread the clamping nut (D, Fig. 24).
5. Remove one e-ring (E, Fig. 24) from spindle.
6. Loosen the two setscrews in the right hand pulley (F, Fig. 24).
7. Use a wood dowel, or aluminum stock to knock the spindle towards the tailstock. *Use a material that is softer than the spindle so you do not mushroom the end of the spindle.* Go only far enough to remove the right hand pulley and belt from spindle, see Figure 25 when changing the belt. **Note:** Mark the key way on the pulley for easy reference when reassembling.
8. Now you can replace the belt or bearings. There are three bearings #6, 9 and 43 that can be seen in the "Headstock Assembly," on page 25.
9. To reassemble reverse the procedure. **Note:** Key way alignment is critical for installment and proper operation. Do not force the pulley. When reinstalling clamping nut thread it on to the spindle until its snug. Then back off slightly and tighten the socket head cap screw.

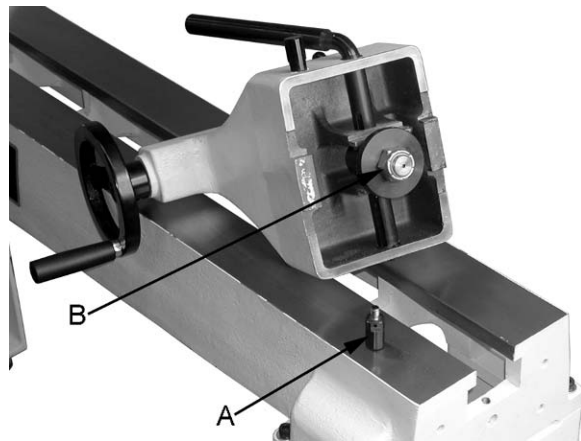

Figure 23

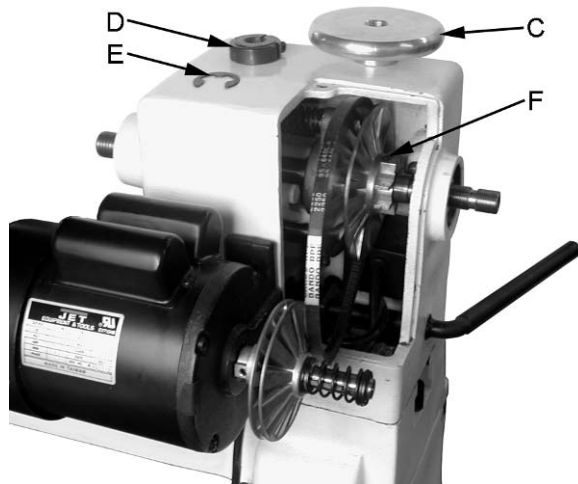

Figure 24



Figure 25

Optional Accessories

Safety Guard

The JWL-1442VS Safety Guard is an optional accessory.

Referring to Figure 26:

1. Mount the guard bracket (A) to the headstock with two 3/8" flat washers, two 3/8" lock washers and two 3/8"-16 x 1-1/2" socket head cap screws (B).
2. Attach the guard (C) to the guard bracket by inserting the rod and lifting up on the plunger (D).
3. There are two detents that will hold the guard in place. One is for turning and the other is for when you need the guard up and out of the way. Simply lift up on the plunger and rotate the guard until the plunger slips into the detent.

Tighten the bushings (E) against the bracket with two setscrews (F).

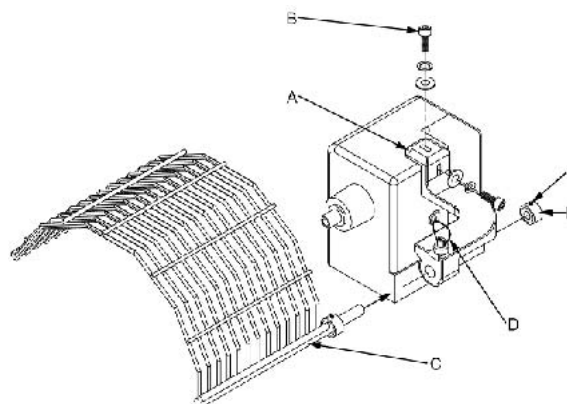

Figure 26

Tool Basket

Referring to Figure 27:

1. Mount the bracket (A) to the inside of the lathe leg with two 5/16"-18 x 1-1/2" Hex Socket Cap Screws, four 5/16" flat washers and two 5/16" hex nuts (B).
2. The two setscrews, on the bracket should be below the bolts and accessible for adjustment.
3. Place the arm of the tool basket into the bracket and tighten with a 5/16"-18 x 5/8" set screw and a 5/16" hex nut (C). Line up the notch in the arm with the setscrews so the tool basket can pivot.
4. Adjust the set screws on the bracket so that the tool basket swings in a level manner. Tighten the two hex socket cap screws.

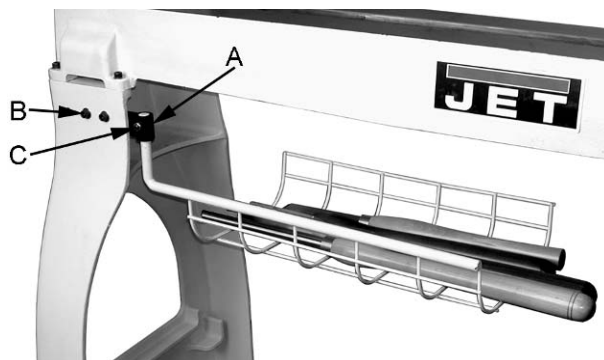

Figure 27

Troubleshooting

Problem	Possible Cause	Solution
Excessive Vibration.	<ol style="list-style-type: none"> 1. Workpiece warped, out of round, has major flaw, improperly prepared for turning, or RPM is set too high 2. Worn spindle bearings 3. Worn belt 4. Motor mount bolts loose 5. Lathe on uneven surface 	<ol style="list-style-type: none"> 1. Correct problem by planing, bandsawing, reduce the RPM, or scrap workpiece all together 2. Replace bearings 3. Replace belt 4. Tighten bolts 5. Shim lathe bed, or adjust feet on stand
Motor or Spindle Stalls or Will not Start	<ol style="list-style-type: none"> 1. Excessive cut 2. Worn motor 3. Broken belt 4. Worn spindle bearings 5. Improper cooling on motor 6. Starting or running capacitor is bad 7. Centrifugal switch bad 	<ol style="list-style-type: none"> 1. Reduce cut depth 2. Replace motor 3. Replace belt 4. Replace bearings 5. Clean sawdust from motor fan 6. Replace the starting capacitor 7. Replace centrifugal switch
Motor fails to develop full power.	<ol style="list-style-type: none"> 1. Power line overloaded 2. Undersize wires in supply system, or extension cord is too long 3. Low voltage 4. Running capacitor is bad 5. Worn motor 	<ol style="list-style-type: none"> 1. Correct overload condition 2. Increase supply wire size 3. Request voltage check from power company and correct low voltage condition 4. Replace running capacitor 5. Replace motor
Tools tend to grab or dig in.	<ol style="list-style-type: none"> 1. Dull tools 2. Tool support set too low 3. Tool support set too far from workpiece 4. Improper tool being used 	<ol style="list-style-type: none"> 1. Sharpen tools 2. Reposition tool support height 3. Reposition tool support closer to workpiece 4. Use correct tool for operation
Tailstock Moves When Applying Pressure	<ol style="list-style-type: none"> 1. Excessive pressure being applied by tailstock. Note: The screw action of the tailstock is capable of applying excessive pressure to workpiece and headstock. Apply only sufficient force by tailstock to hold workpiece securely in place. Excessive pressure can cause damage to machine. 2. Lathe bed and tailstock mating surfaces are greasy or oily. 	<ol style="list-style-type: none"> 1. Slide tailstock down to the right side of the lathe against the stop. Move headstock into position and apply pressure to workpiece with tailstock. 2. Remove and clean surfaces with a cleaner degreaser

Parts

Ordering Replacement Parts

To order parts or reach our service department, call 1-800-274-6848 Monday through Friday (see our website for business hours, www.waltermeier.com). Having the Model Number and Serial Number of your machine available when you call will allow us to serve you quickly and accurately.

Bed Assembly Parts List

Index No.	Part No.	Description	Size	Qty
1	JWL1442-201	Bed		1
2	JWL1442-202	Stud		3
3	JWL1442-124	C-Ring	S19	3
4	6295703	Hex Socket Cap Screw	10-24 x 5/8"	4
5	JWL1442-205	Tool Rest		1
6	JWL1442-206	Tool Support Handle		1
7	JWL1442-207	Tool Support Base		1
8	JWL1442-208	End Cover		1
9	JWL1442-128	Bolt		2
10	JWL1442-210A	Tool Support Rod		1
11	JWL1442-211	Handle		1
12	JWL1442-212	Handwheel		1
13	JWL1442-213	Tailstock		1
14	JWL1442-214	Lead Screw		1
15	JWL1442-215	Quill		1
16	JWL1442-216	Live Center		1
17	JWL1442-217	Tailstock Rod		1
18	JWL1442-218	Tailstock Quill Handle		1
19	JWL1442-219	JET Label		1
20	TS-0267021	Set Screw	1/4"-20 x 1/4"	2
21	JWL1442-127	Bushing		1
22	JWL1442-126	Key	5 x 5 x 30	1
23	JWL1442-154	Clamp		2
24	TS-0561081	Hex Nut	3/4"-10	2
26	JWL1442-226	Extension Tool Rest		1
27	JWL1442-227	Locking Handle		1
28	JWL1442-228	C-Ring	S25	1
	JWL1442-TCA	Tailstock Complete Assembly (not shown)		1
	JWL1442-TRCA	Tool Rest Complete Assembly (not shown)		1

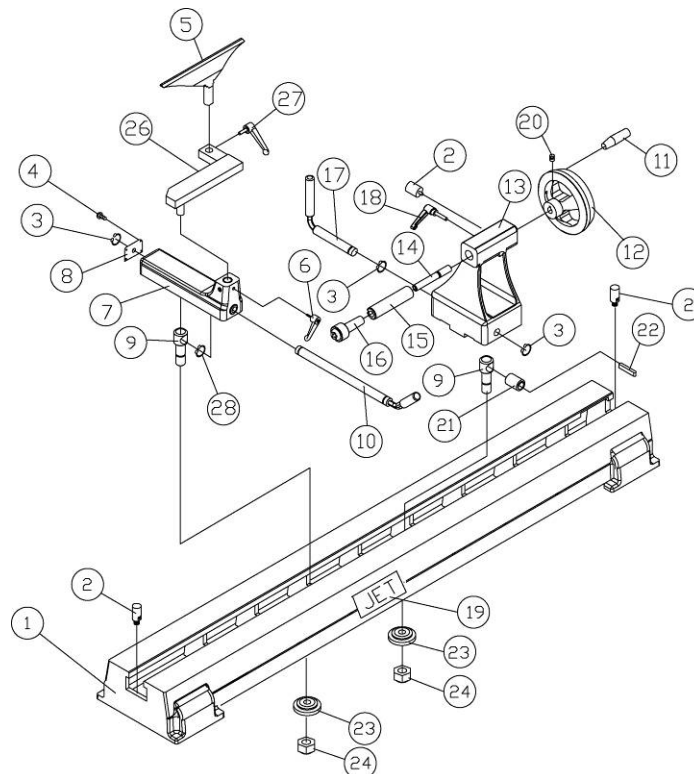

Headstock Assembly – Parts List

Index No.	Part No.	Description	Size	Qty
1	JWL1442-101	Spur Center	MT2	1
2	JWL1442-102	Face Plate	6"	1
3	JWL1442-103	Spindle		1
4	JWL1442-104	Key	4 x 4 x 80	1
5	JWL1442-105	E-Ring	E-19	1
6	BB-6205ZZ	Ball Bearing	6205ZZ	1
7	JWL1442-107	Headstock		1
8	JWL1442-108	Wave Washer		1
9	BB-6304LLB	Ball Bearing	6304LLB	1
10	JWL1442-110	Lock Nut	3/4"-16	1
11	JWL1442-111	Hand wheel		1
12	TS-0207031	Hex Socket Cap Screw	1/4"-20 x 5/8"	1
13	JWL1442-113A	Speed Selector Assembly		1
14	JWL1442-114	Handle		1
15	TS-081C052	Round Head Machine Screw	10-24 x 3/4	2
16	JWL1442-116	Spring		1
17	JWL1442-117	Switch Bracket		1
18	JWL1442-118	Switch Assembly		1
19	TS-081C022	Round Head Machine Screw	10-24 x 3/8"	2
20	TS-081C052	Round Head Machine Screw	10-24 x 3/4"	2
21	JWL1442-121	Bracket		1
22	JWL1442-122	Spindle Lock Pin		1
23	TS-0206031	Hex Socket Cap Screw	10-24 x 5/8"	2
24	JWL1442-124	C-Ring	S19	2
25	JWL1442-125	Lever		1
26	JWL1442-126	Key	5 x 5 x 30	1
27	JWL1442-127	Bushing		1
28	JWL1442-128A	Bolt		1
29	JWL1442-129	Support Bracket		1
30	JWL1442-130	Index Bracket		1
31	TS-0561081	Hex Nut	3/4"-10	1
32	TS-0267021	Set Screw	1/4"-20 x 1/4"	6
33	JWL1442-133	Motor Cord		1
34	JWL1442-134	Key	4 x 4 x 80	1
35	JWL1442-135	Motor	1HP, 1Ph	1
	JWL1442-MF	Motor Fan (not shown)		1
	JWL1442-MFCA	Motor Fan Cover (not shown)		1
	JWL1442-CS	Centrifugal Switch (not shown)		1
	JWL1442-CC	Capacitor Cover (not shown)		2
	JWL1442-SC	Starting Capacitor (not shown)	200MFD, 125VAC	1
	JWL1442-RC	Running Capacitor (not shown)	25uF, 250VAC	1
36	JWL1442-136	Switch Box		1
37	JWL1442-137	Spring		1
38	JWL1442-138	Sleeve		1
39	JWL1442-139	C-Ring	S16	1
40	JWL1442-140	Power Cord		1
41	JWL1442-141	Belt	3V-250	1
42	JWL1442-142	Spring		1
43	BB-6006LLB	Ball Bearing	6006LLB	1
44	JWL1442-144	C-Ring	S32	1
45	JWL1442-145	Shifting Lever Bracket		1
46	JWL1442-146	Rack		1
47	JWL1442-147	Strain Relief Bushing		2
48	TS-0207061	Hex Socket Cap Screw	1/4"-20 x 1"	1
49	TS-0561011	Hex Nut	1/4"-20	1
50	JWL1442-150	Pulley Cover		1

Headstock Assembly – Parts List

Index No.	Part No.	Description	Size	Qty
51	TS-0081031	Hex Head Bolt	5/16"-18 x 3/4"	2
52	TS-0720081	Lock Washer	5/16"	2
53	JWL1442-153	Plate		1
54	JWL1442-154	Clamp		1
55	JWL1442-155	JET Label		1
56	JWL1442-156	Warning Label		1
57	JWL1442-157	Speed Label		1
58	JWL1442-158	Motor Label		1
59	JWL1442-159	Motor Pulley (left)		1
60	JWL1442-160	Motor Pulley (right)		1
61	JWL1442-161	Spindle Pulley (left)		1
62	JWL1442-162	Spindle Pulley (right)		1
63	TS-081C022	Round Head Machine Screw	10-24 x 3/8"	4
64	JWL1442-164	Knock Out Rod		1
65	TS-081C082	Pan Head Screw	10-24 x 1-1/2"	1
66	JWL1442-166	Clip		1
67	TS-056007	Hex Nut	10-24	2
68	JWL1442-168	Spanner Wrench		1
69	JWL1442-169	Index Pin		1
70	JWL1442-170	Star Washer	3/16"	1
71	JWL1442-171	Hex Socket Cap Screw		1
72	JWL1442-172	Spring		1
73	JWL1442-173	Index Knob		1
74	JWL1442-174	Index Shaft		1
75	JWL1442-175	Spring		1
76	JWL1442-176	Index Bushing		1
77	JWL1442-PL	Headstock Pivot Label		1
78	JWL1442-178	Spring Pin	Ø3x25	1
79	JWL1442-179	Fixed Block		1
80	JWL1442-180	Rod		1
81	JWL1442-181	Spring		1
82	JWL1442-182	Spring		1
83	JWL1442-183	Pin		1

Headstock Assembly

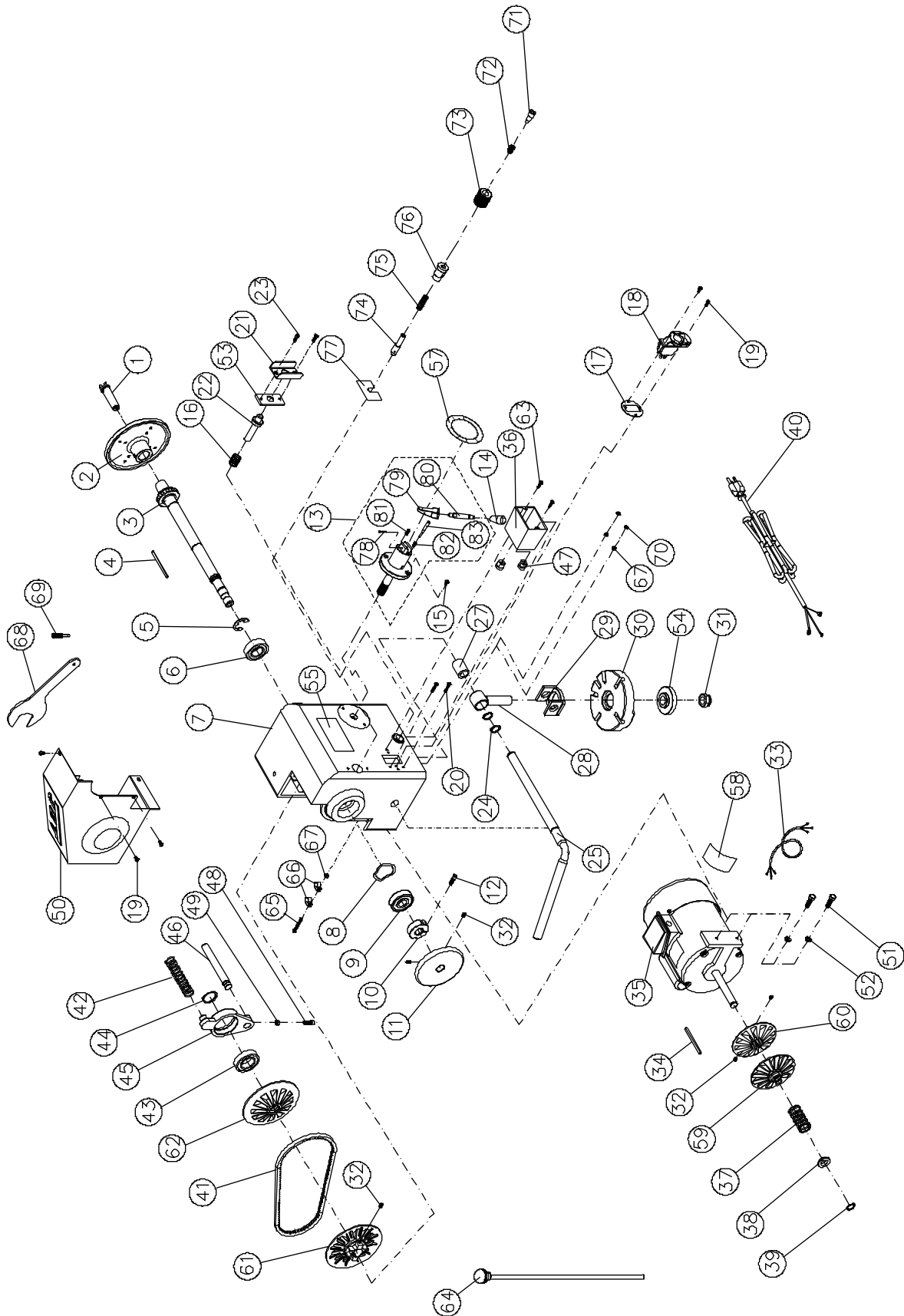

Stand Assembly

Index No.	Part No.	Description	Size	Qty
3.....	JWL1642-203.....	Stand.....		2
5.....	JWL1642-205.....	JET Stripe.....		1
6.....	JWL1642-206.....	Adjustable Foot.....	3/8"	4
7.....	TS-0561031.....	Hex Nut.....	3/8"	4
9.....	TS-0208081.....	Hex Socket Cap Screw.....	5/16"-18 x 1-1/2"	8
10.....	TS-0680032.....	Flat Washer.....	5/16"	8

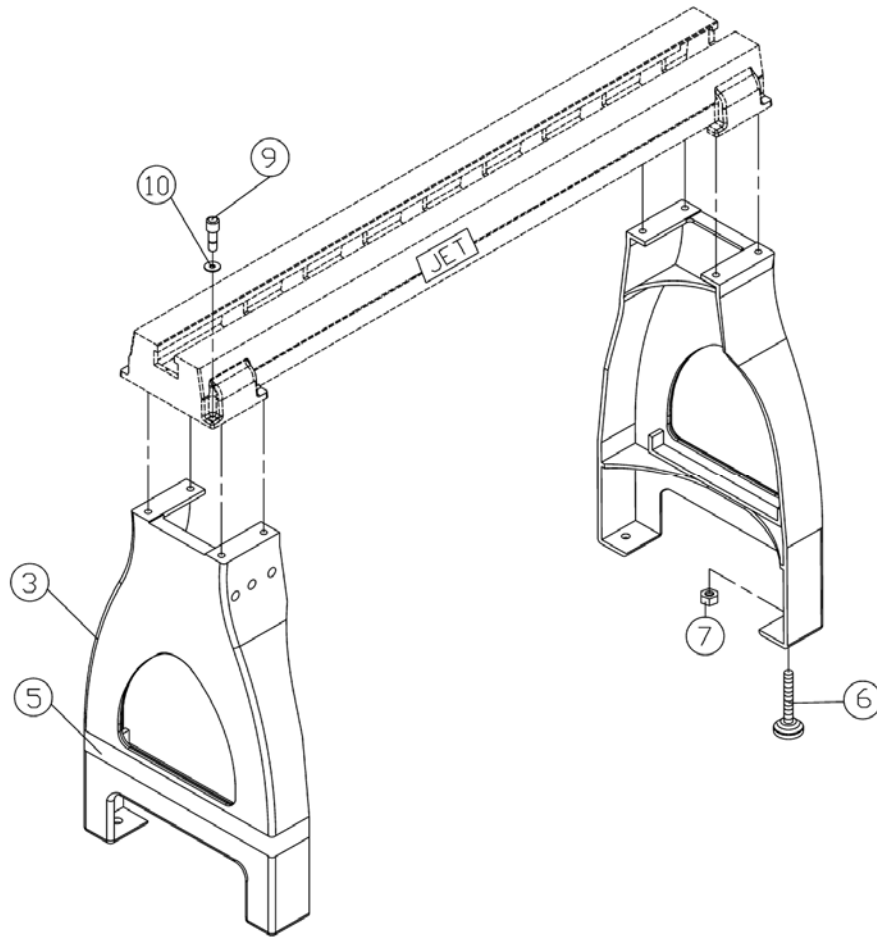

Safety Guard Assembly

Index No.	Part No.	Description	Size	Qty
1.....	JWL1442-301	Guard Bracket		1
2.....	TS-0270011	Set Screw	5/16"-18x1/4".....	2
3.....	JWL1642-187	Collar		2
4.....	TS-0680041	Flat Washer.....	3/8".....	2
5.....	TS-0720091	Lock Washer	3/8".....	2
6.....	TS-0209071	Socket Head Cap Screw	3/8"-16x1-1/2".....	2
7.....	JWL1642-168	Plunger		1
8.....	JWL1642-179	Guard		1

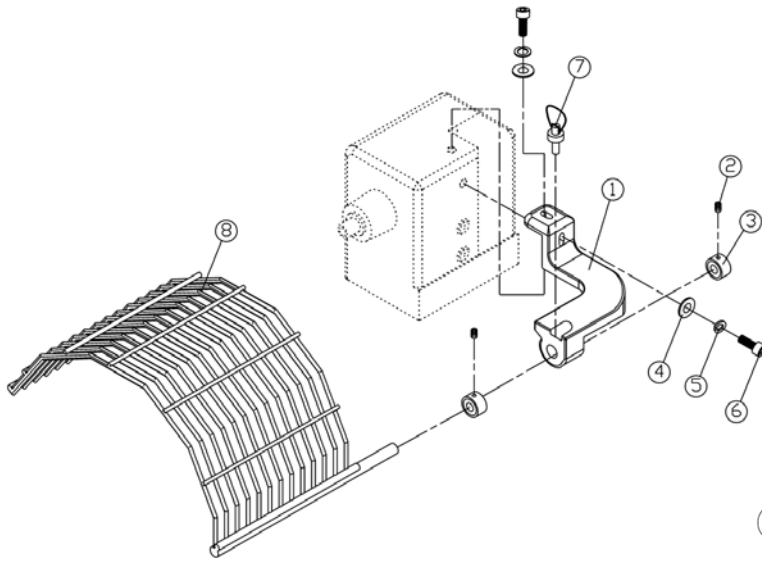

Safety Guard Assembly

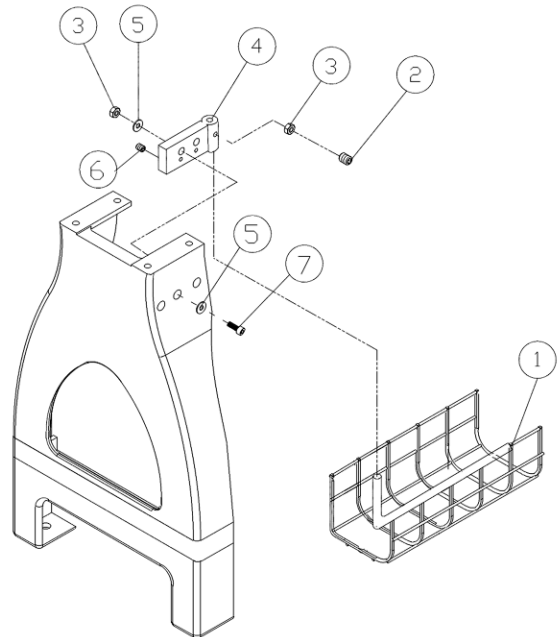

Basket Assembly

Basket Assembly

Index No.	Part No.	Description	Size	Qty
1.....	JWL1642-228	Basket		1
2.....	TS-0270061	Set Screw	5/16"-18x5/8".....	1
3.....	TS-0570021	Hex Nut.....	5/16".....	3
4.....	JWL1642-226	Bracket		1
5.....	TS-0680032	Flat Washer.....	5/16".....	4
6.....	TS-0267021	Set Screw	1/4"-20x1/4".....	2
7.....	TS-0208081	Hex Socket Cap Screw	5/16"-18x1-1/2".....	2

Wiring Diagram

115Volt Operation

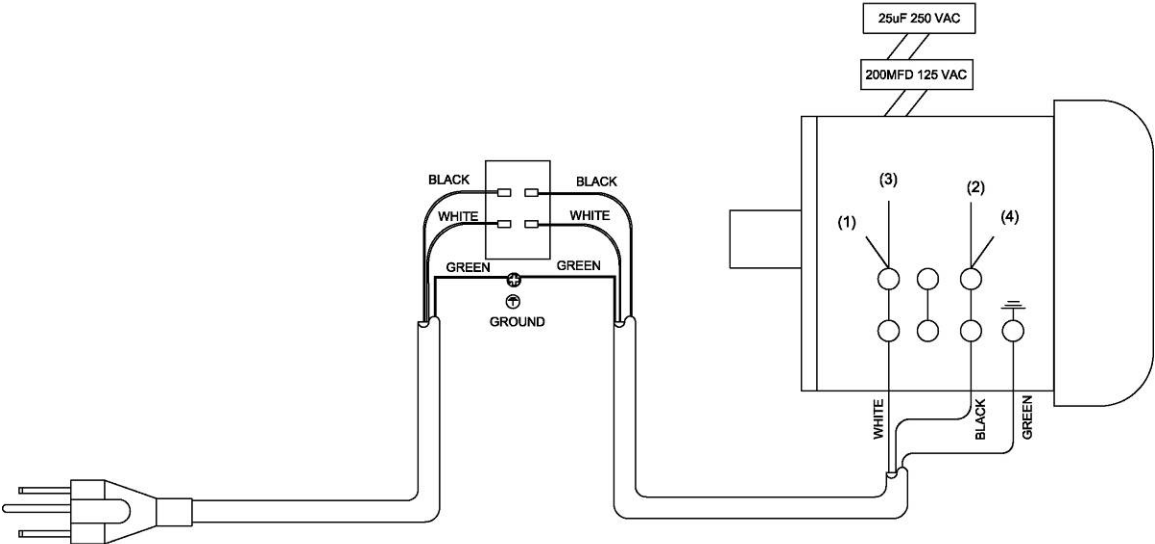

230Volt Operation

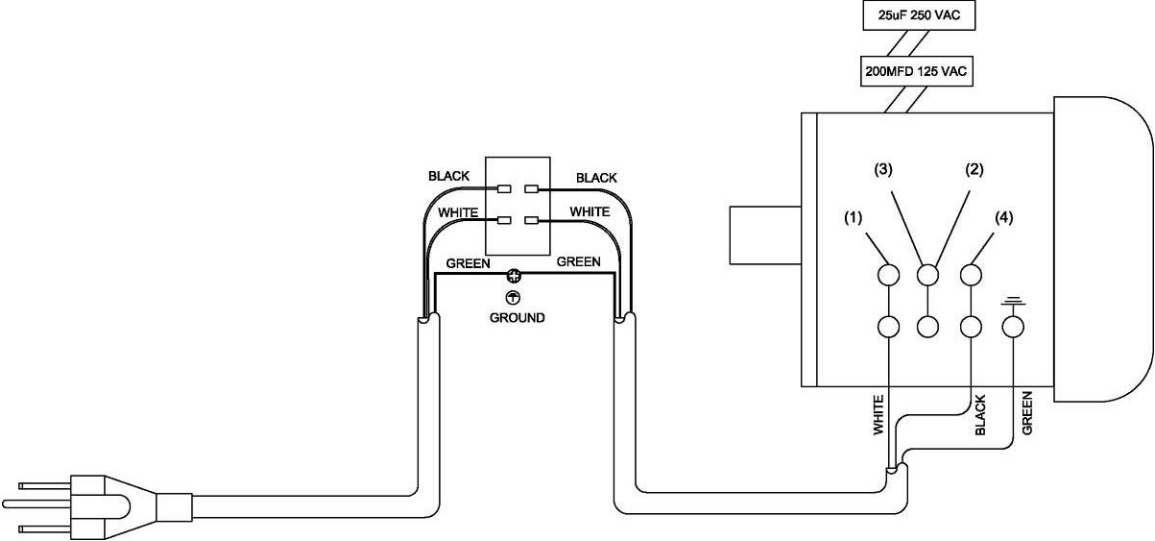

Appendix – Indexer Positions

How to use the chart

A diagram of the indexer is shown at right, as viewed from the tailstock end of the Lathe. Points A, B and C are the holes in the head casting. The holes in the spindle collar may be considered as numbered 1 through 12.

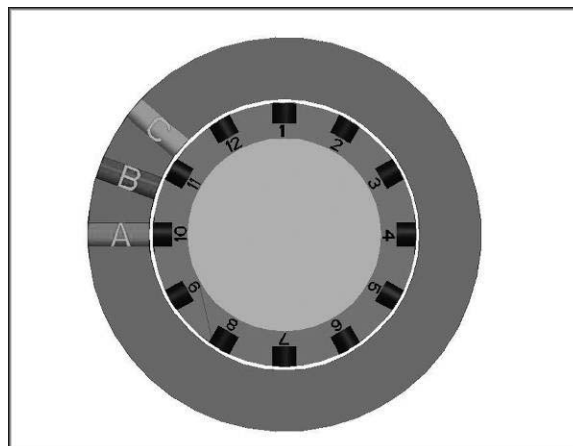

Example: You wish to rout 9 flutes on your spindle blank. Locate the “9” in the “No. of Flutes” column; each flute angle will be 40°. The index pin should first be inserted into hole combination “A-1”. Make your first flute at this position. Back off the index pin and rotate the spindle until the index pin can be inserted into hole combination “A-5”; this will be followed by “A-9”. Succeeding flutes will be made with the index pin in the B position: “B-3”, “B-7” and so on

No. of Flutes 360° divided by...	Angle	Letter #	Letter #	Letter #
1	360.00	A	1	
2	180.00	A	1,7	
3	120.00	A	1,5,9	
4	90.00	A	1,4,7,10	
5	72.00	-----		
6	60.00	A	1,3,5,7,9,11	
8*	45.00	A	1,4,7,10	
9	40.00	A	1,5,9	B 3,7,11 C 1,5,9
10	36.00	-----		
12	30.00	A	1 to 12	
15	24.00	-----		
16	22.50	-----		
18	20.00	A	1,3,5,7,9,11	B 1,3,5,7,9,11 C 1,3,5,7,9,11
20	18.00	-----		
24*	15.00	A	1 to 12	
30	12.00	-----		
36	10.00	A	1 to 12	B 1 to 12 C 1 to 12
<i>other interesting patterns...</i>				
9	-----	A	1,5,9	B 1,5,9 C 1,5,9

NOTE: A dashed line indicates that particular set of angles is not possible with the indexer.

* For 8 or 24 flutes, perform the first sequence, then rotate the workpiece by hand to the needed position and repeat the same sequence.

Notes

Notes



WALTER MEIER (Manufacturing) Inc.

427 New Sanford Road
LaVergne, Tennessee 37086

Ph.: 800-274-6848

www.jettools.com

www.waltermeier.com